

Sorane

TA-1 & TA-1L

INSTRUCTIONS & MANUAL

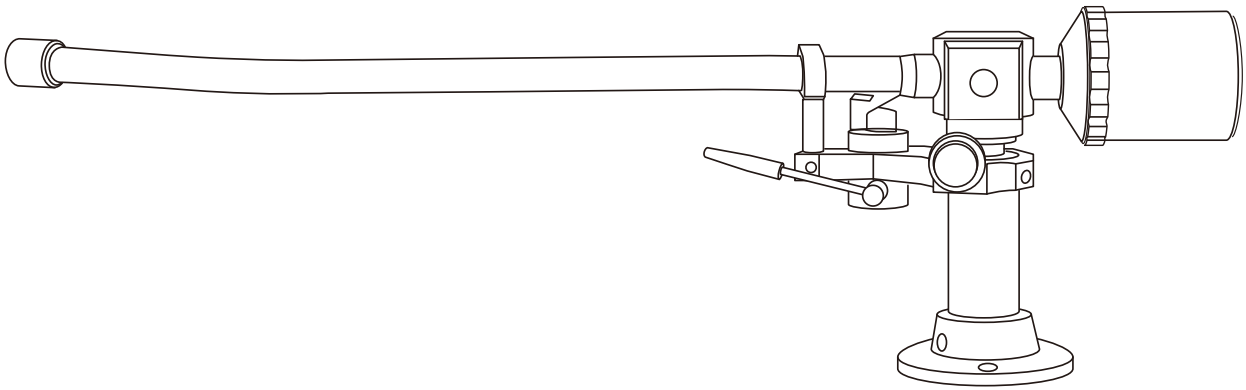

s p e c i f i c a t i o n s

	TA-1	TA-1L
Total Length	288mm	380mm
Spindle to pivot distance	216mm	310mm
Stylus to pivot distance	232mm	322mm
Overhang	16mm	12mm
Offset angle°	22°	16.5°
Cartridge weight range	15-32g with headshell	15-32g with headshell 55g with option 325g weight
Total weight	580g with headshell attached:597g	610g with headshell attached:627g
Antiskating	up to 3g	up to 3g
Tonearm Audio Lead wire	OFC 4N Copper	
Headshell lead wire	AWG30 Copper	

Thanks to Cylinder type Base's wider area bite between Sorane column shaft and TT plinth, sound improvement and stability would become dramatic by this parts.

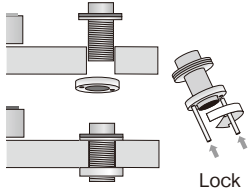

Lock

Option

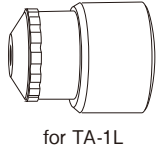

for TA-1L

TA-1

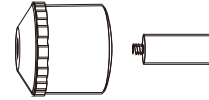

TA-1L

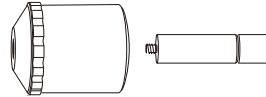

Option

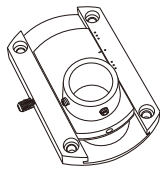
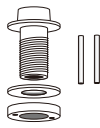

Base



Marking Pin

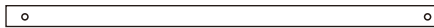

Template

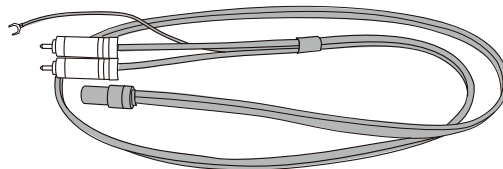

Detachable phono cable



Allen Keys

Screws, Washers

Included Accessories

TA-1 or TA-L

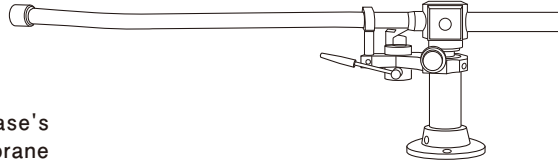

Headshell

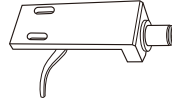

Weight

Base

Marking Pin

Template

Detachable phono cable

Allen Keys

Screws, Washers

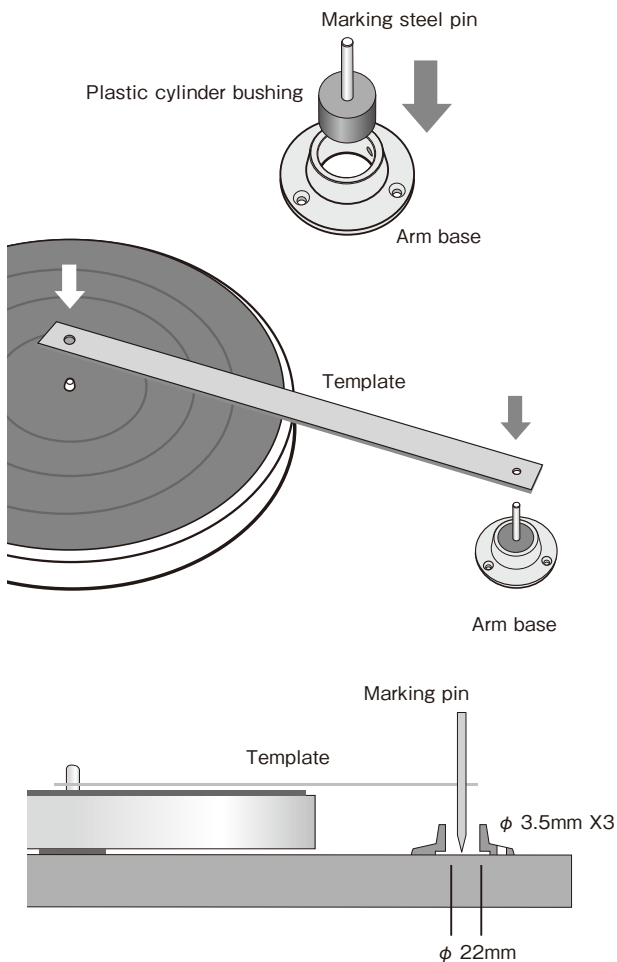

Mounting the tonearm base to turntable plinth

1-a Determine where the arm base should be placed by using the arm template supplied.

1-b Put the hole of the template over the spindle. Use the supplied steel pin (as illustrated) and push it through the tonearm pivot hole on the opposite end of the template. Using the supplied plastic bushing, keep the needle perpendicular to the template and mark the position of center on the turntable.

1-c At the same time, 3 holes for fixing screws should also be marked.

1-d Having marked the center, check that if the tone arm is placed in this position, that it will clear the dust cover.

1-e Drill a 22mm hole and three 3.5mm hole.

* Drilling a hole: 22mm diameter (For tonearm shaft)

* Drilling 3 x 3.5mm diameter (For tonearm base fixing screws)

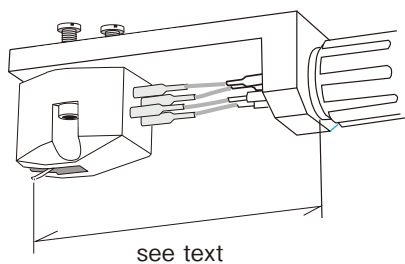

Attach the cartridge to headshell

2-a Connect the leads to the cartridge and attach the cartridge to the correct position of headshell with screws, as in the figure .

•Screws are not included in this tone arm kit

•Mounting distance, from collet ring, to stylus tip, is 50mm for the TA1.

•Mounting distance, from collet ring, to stylus tip, is 46mm for the TA1L.

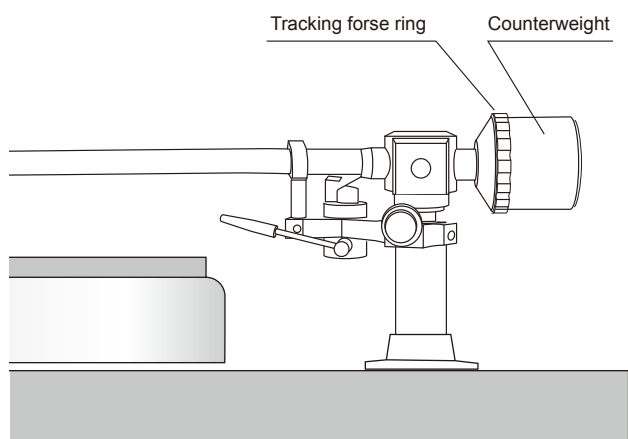

Mount TA-1 shaft through the Base hole

3-a Locate the tonearm shaft through the hole in the arm base and then fasten the screw with hex key.

3-b Adjust the arm height as turntable plinth surface and tonearm wand should be level.

* Cueing platform has already been set at the correct height but can be adjusted by using the wrench supplied.

Cartridge tracking force adjustment

4-a Ensure that the tracking force adjustment knob is set to the zero position.

4-b With the cartridge permanently fitted in the correct position, adjust the counterweight so that the arm is floating with the stylus approximately 3–5mm above a vinyl record. (This adjustment should be made with the anti-skating knob to zero.)

4-c Rotate the counterweight and move it forward. Each graduation is equivalent to 0.25 grams tracking force.

* The applied range of weight of headshell with cartridge is from 15grams - 32grams (TA-1). And 15grams - 35(TA-1L).

For TA-1L, maximum total weight is 55 grams with option "325" weight.

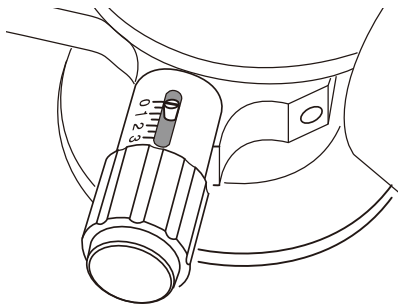

Anti-Skating (bias) adjustment

5-a Set the bias adjustment knob to the same number as the required tracking force.

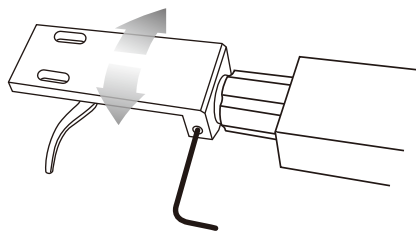

Headshell Azimuth Adjustment

6-a Sorane tonearms come with azimuth adjustable headshells. There is an Allen or hex set-screw in the side of the headshell. There is a corresponding Hex Key to allow the user to adjust the headshell.

6-b As shipped from the factory, the headshell adjustment Hex set-screw is set to approximately 90 degrees, with the intention that customers should adjust the headshell to match their unique setup (cartridge, plinth, platter, etc.). Customers are requested to make final adjustments after mounting the cartridge, then installing the headshell on your Sorane tonearm. It is important to make sure the stylus is perpendicular to the surface of the record. Often it is helpful to use a mirror (if you do not have a mirror, a CD will also work). The main thing is to understand that many stylus assemblies are not perfectly perpendicular, and sometimes platters are concave, so that it is important to adjust the stylus until it is perpendicular with the groove.

Thank you for choosing Sorane! As IT Industry values the customer, and strives to offer the best performance, we are sure you will enjoy many hours of clear and dynamic sound.

Happy listening!

TA-1 Counterweight

Standard Main Counterweight

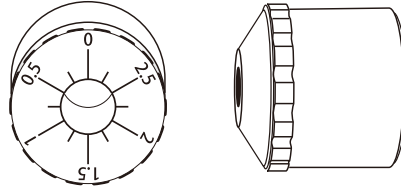

□ 3g Stylus force is added
by 1 Counter Weight rotation

Standard subweight "S"

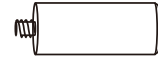

□ Available cartridge weight
(With headshell) is up to 32g
with "S" subweight.

TA-1L Counterweight

Standard main counter weight

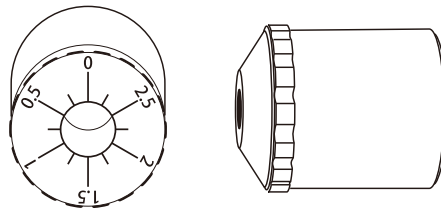

□ 3g Stylus force is added
by 1 Counter Weight rotation

Standard subweight "L"

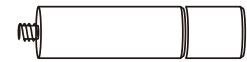

□ Available cartridge weight
(With headshell) is up to 35g
with "L" subweight.

TA-1L Optionally ordered counter weight

Optionally ordered
Subweight "325"

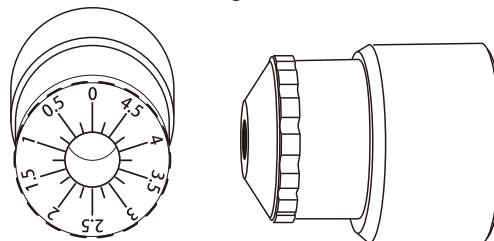

□ 5g Stylus force is added
by 1 Counter Weight rotation

* Available cartridge weight
(with headshell)
is up to 55g with "325"
optional weight plus
"201" subweight.

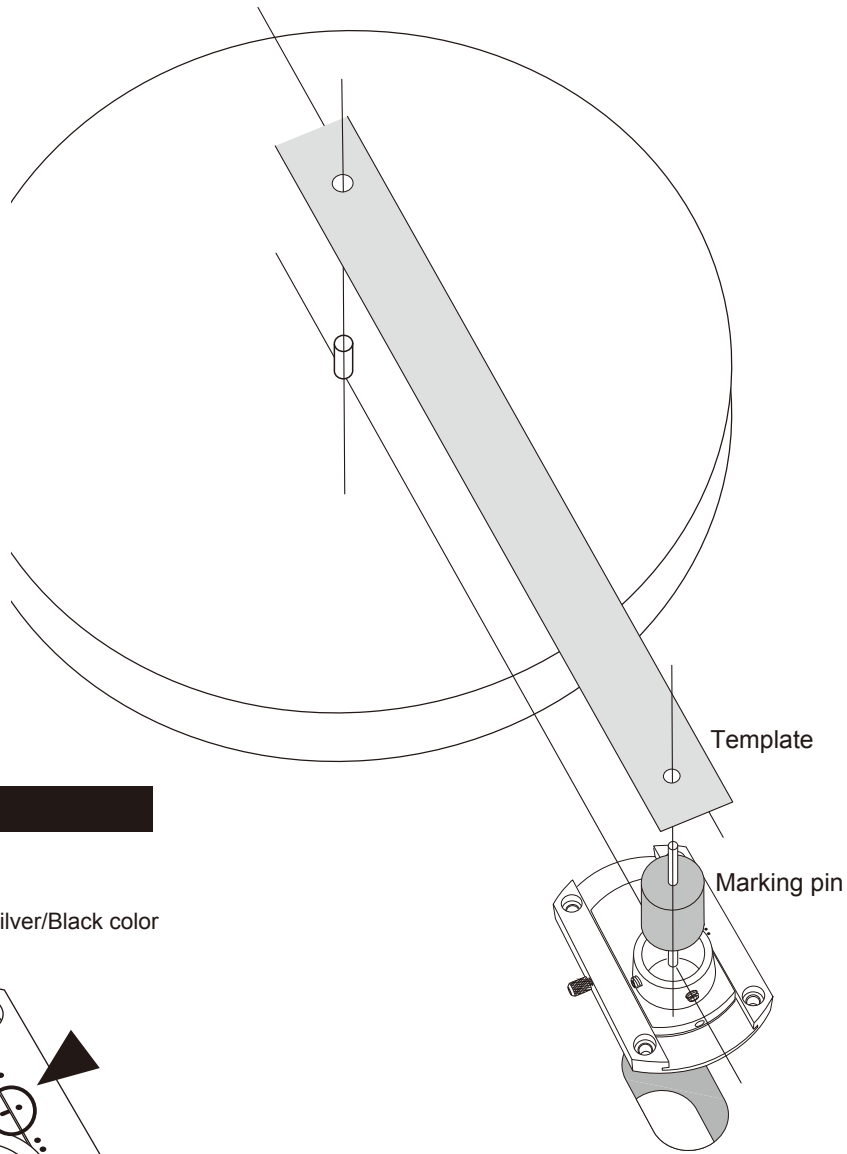

OPTION

SSBS/B

Sorane Sliding Base with Silver/Black color

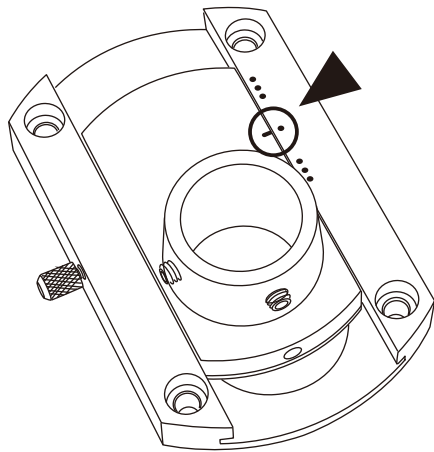

SSBS/B(Sorane Sliding Base with Silver/Black color) is optional parts to replace SME standard base for customer's convenience.

Direction of sliding sub-base should point to the turntable spindle, while the mounting distance (the middle of the range of travel for the sliding base), is set by the mounting template.

step1 Marking

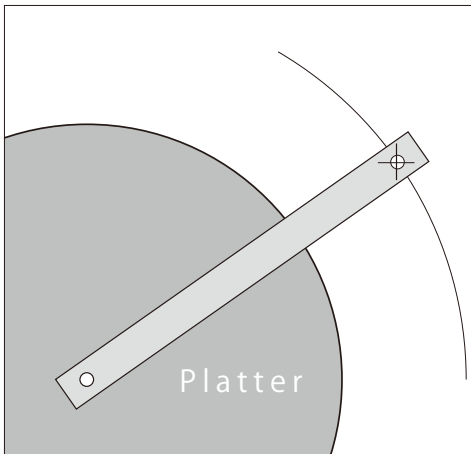

step2 Drilling

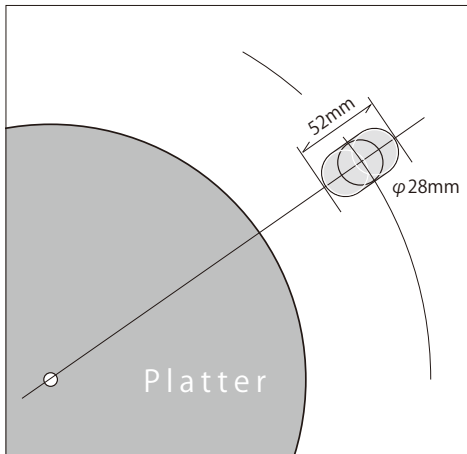

step3 Set up

